

REVISIONS				
ECR/DCR	REV.	DESCRIPTION	DATE	APPD
-	-	INITIAL RELEASE	-	-

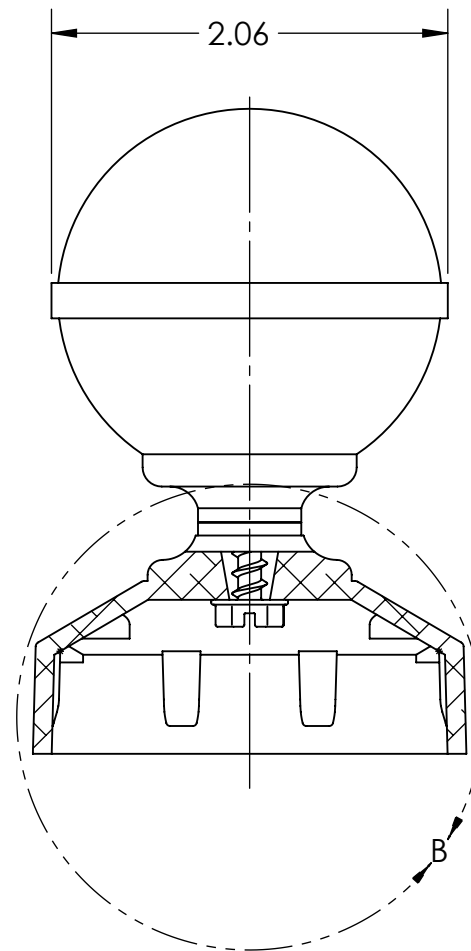

**SECTION A-A**

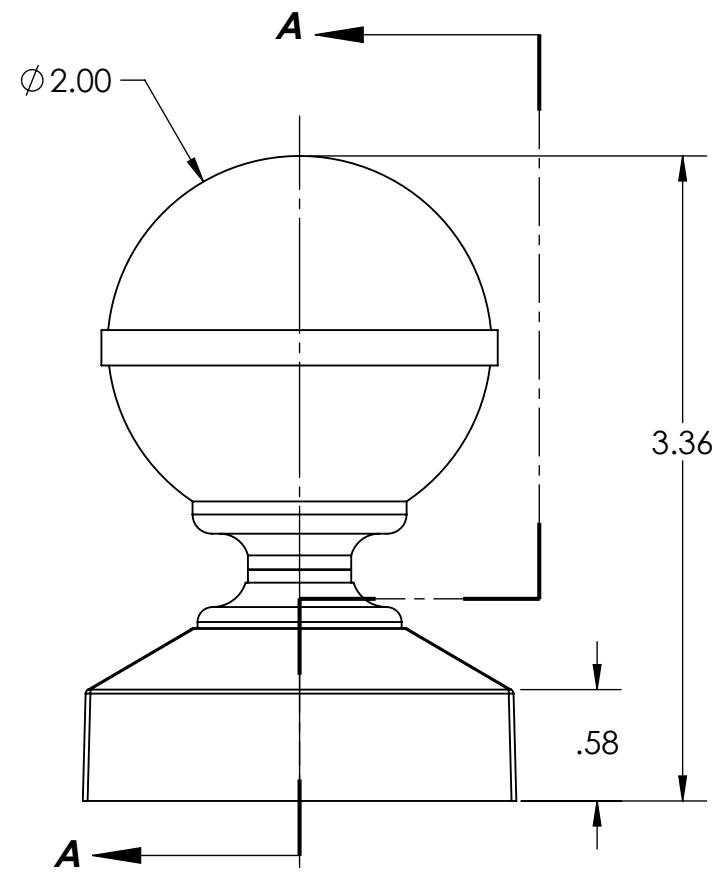
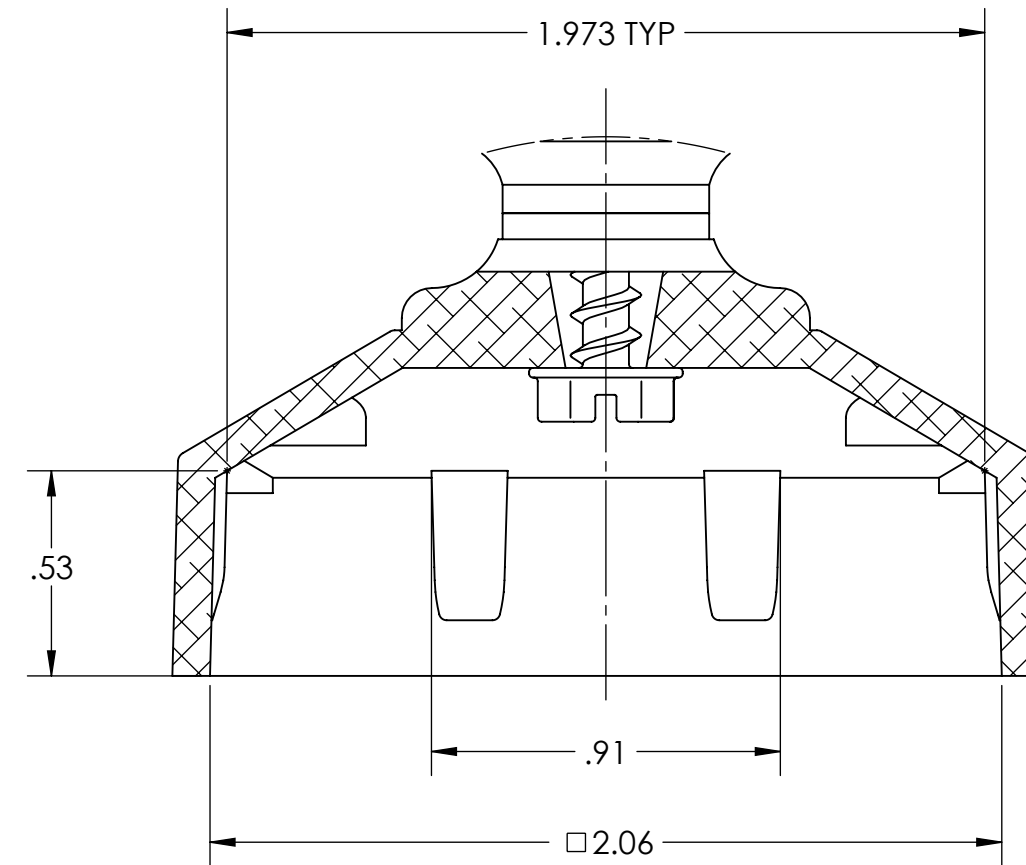

**DETAIL B  
SCALE 2 : 1**

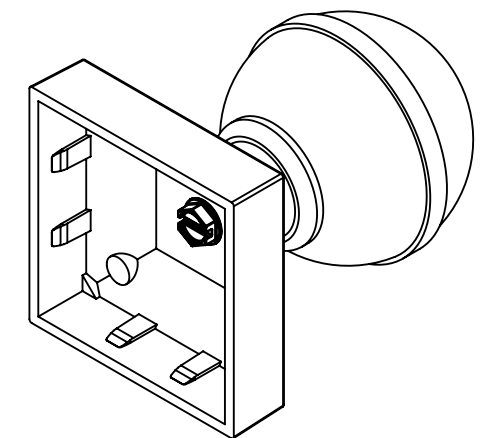
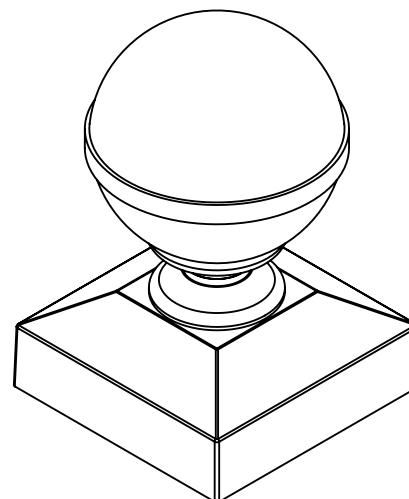
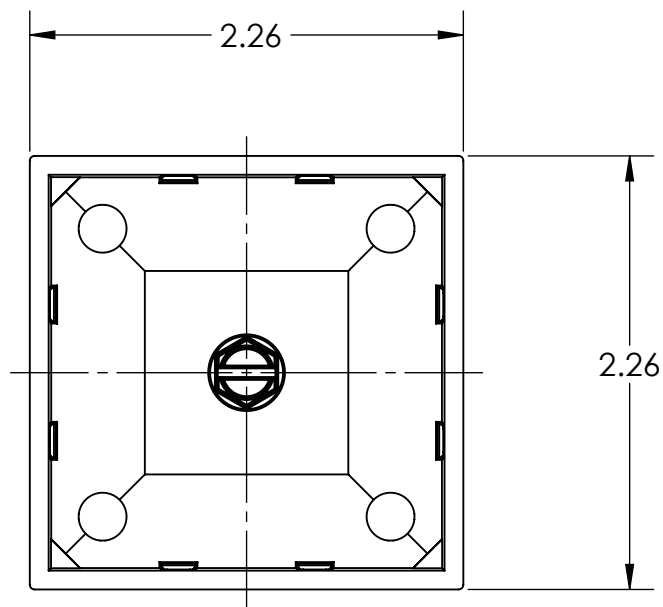

DIMENSIONS ARE IN INCHES TOLERANCES: FRACTIONAL: ±1/16" ANGULAR: MACH ±1° BEND ±1° TWO PLACE DECIMAL ±0.01 THREE PLACE DECIMAL ±0.005	NAME	DATE	<b>2" LIGHT WEIGHT BALL CAP</b>  <b>BPC2BL</b>
	DRAWN		
	CHECKED		
	ENG APPR.		
	MFG APPR.		
MATERIAL	Q.A.		SIZE DWG. NO. REV. <b>B</b> -
FINISH	COMMENTS:		
DO NOT SCALE DRAWING			SCALE: 1:1 WEIGHT: LB. SHEET 1 OF 1