

| ECR/DCR | | REV. | REVISIONS | DESCRIPTION | DATE | APPD |
|---------|---|------|-----------------|-------------|------|------|
| - | - | - | INITIAL RELEASE | | - | - |

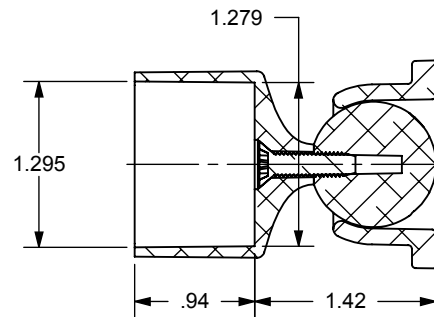

SECTION A-A

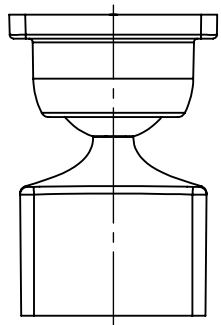
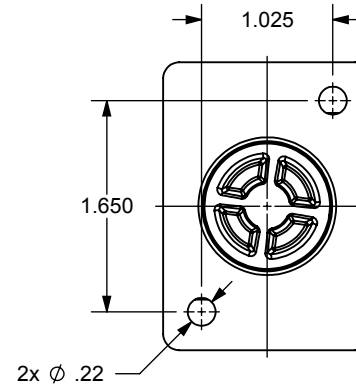
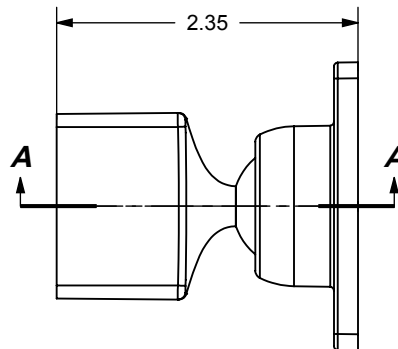
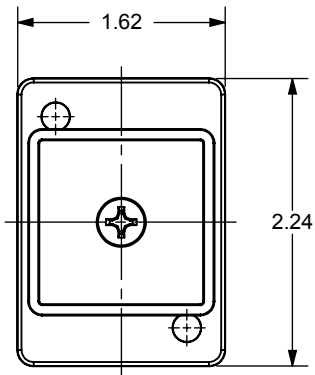
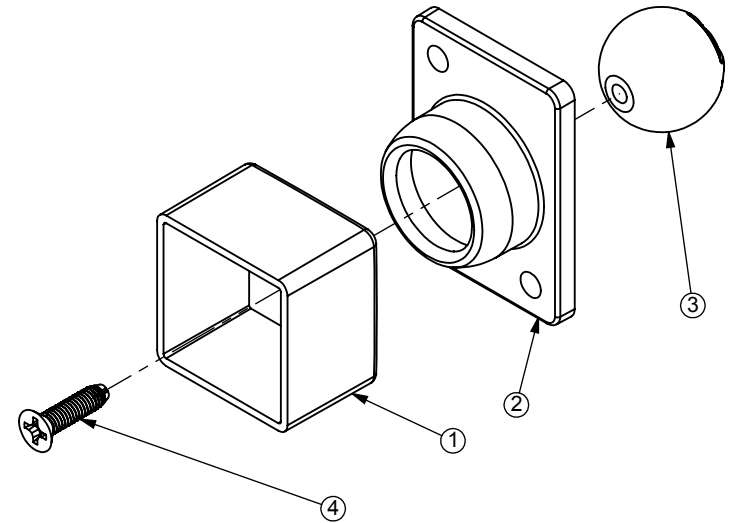

| ITEM # | DESCRIPTION | QTY. |
|--------|------------------------|------|
| 1 | 1.25 X 1.25 SWIVEL CUP | 1 |
| 2 | BASE MOUNT | 1 |
| 3 | BALL | 1 |
| 4 | SCREW | 1 |

| | | | |
|--|----------|--|--|
| DIMENSIONS ARE IN INCHES TOLERANCES: FRACTIONAL $\pm 1/16"$ ANGULAR: MACH $\pm 1^\circ$ BEND $\pm 1^\circ$ TWO PLACE DECIMAL ± 0.01 THREE PLACE DECIMAL ± 0.005 | | 1.25" X 1.25" SWIVEL BRACKET ASSEMBLY | |
| | | SWB-114-BLACK | |
| SIZE | DWG. NO. | REV. | |
| A | | - | |
| SCALE: 2:3 | WEIGHT: | SHEET 1 OF 1 | |