

durables[®]

Sterling Aluminum Straight Railing

Installation Guide

THE BEST CHOICE FOR STRONG & DURABLE RAILING SYSTEMS

Our exclusive manufacturing process ensures our aluminum railing will provide superior strength plus it is virtually maintenance free. This guide will help make your installation easy.

Please note:

It is the responsibility of the installer to conform to local building codes and safety requirements. It is also the installer's responsibility to obtain all necessary building permits. All of our straight aluminum railing sections 8 ft. long and below meet IRC building codes. The purchaser and installer should review the intended use of the products with a licensed professional engineer to determine code compliance. Durables® or its distributors shall not be held liable for improper or unsafe installations.

These instructions are guidelines and do not cover every installation scenario. Review all instructions before starting railing installation. The installer may need to modify the exact installation method to meet unique site requirements. Railing has been tested by PEI and meets 2016 IRC Construction Code Standards.

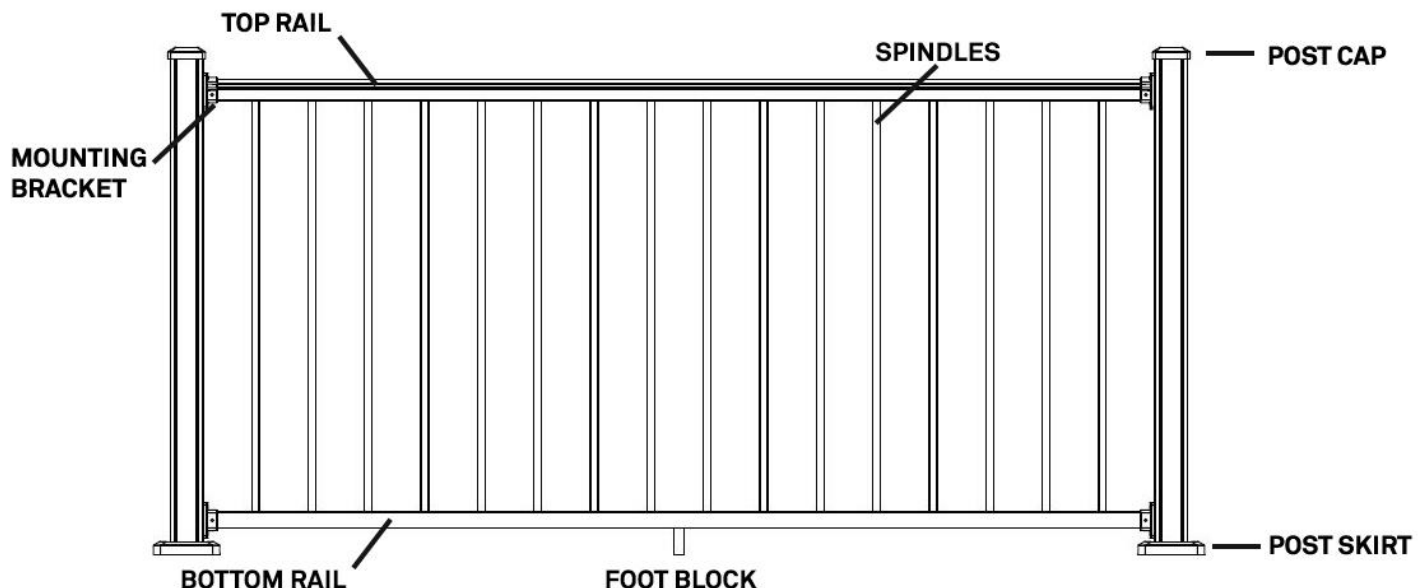

Installation Tips:

1. A miter saw with high tooth count carbide blade can be used to cut the aluminum. Cut slowly and use all safety precautions
2. If your installation requires that the rails be cut, be sure to double check all measurements before cutting.
3. Only use the fasteners provided in the railing kit. Do not overtighten the screws.
4. Applying paint, other than manufacturer's touch up paint, will void the warranty.
5. The screws included require a T25 torx drive bit, which is not included in the railing kit.
6. Foot block assembly is manufactured for a 2" gap between the mounting surface and the bottom rail.
7. All fasteners are self-tapping, we recommend drilling pilot holes with a 1/8" bit (not included).

INCLUDED COMPONENTS

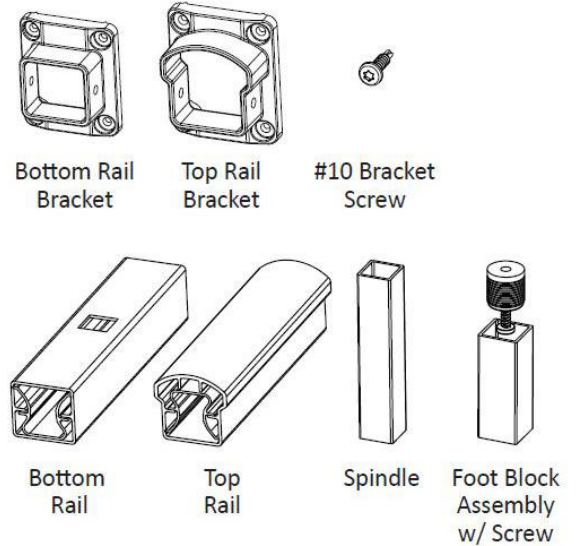

Recommended Tools:

- Safety Glasses
- Level
- Tape Measure
- Miter saw with high tooth count carbide blade
- Rubber Mallet
- Power Drill
- Phillips Drive Bit
- T25 Torx screwdriver bit

Section 1

1. Install posts (see post instructions included with post). Ensure that posts are installed with the one piece post skirt in place. It's important that the post skirts are in place prior to installing the railing sections since they are one piece they cannot be added after the railing is installed.
2. Measure the distance between the posts to determine the width of your rails.

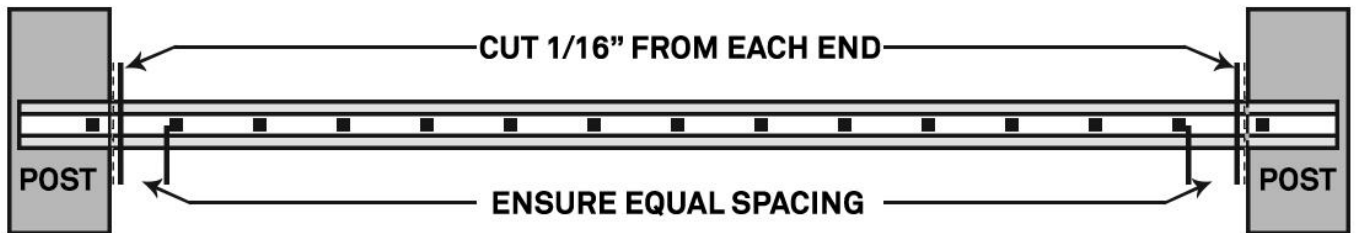

3. Subtract 1/16" from each end of the rail to avoid scratching the posts when installing the brackets in Sections 3 and 4.
4. If you need to shorten the width of the rails, mark the rails being sure to subtract an equal amount from each end. This will keep the spindles centered.
5. If the cut mark is on a spindle hole, adjust the position of your cut lines accordingly.
6. Mark both the top and bottom rails to the same length and confirm that the spindle holes line up.
7. Cut the aluminum rails and the vinyl inserts to the same length. Be sure to cut slowly and use all safety precautions.

Section 2

1. The typical distance between the mounting surface and the bottom of bottom rail is 2".

Note: Default finished rail height will be 36" for our 36" tall railing and 42" for our 42" railing with the 2" foot block.

2. If there is a spindle hole in the center of the bottom rail, the foot block must be centered on that spindle hole to not interfere with the foot block screw.
3. Center the foot block connector on the bottom of the bottom rail and secure it with the provided self-drilling screw.
4. Use a rubber mallet to lightly tap the 2" foot block over the foot block connector and into place.
5. In areas with freezing temperatures, drill a 1/8" weep hole around 3 inches from each end of the bottom of the bottom rail, make sure it goes through the plastic insert.

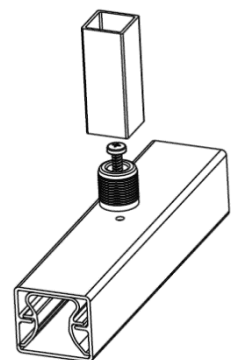

Section 3

1. Slide the brackets on to each end of the bottom rail, ensuring the back of the bracket is facing the posts.
2. Position the bottom rail between the posts, placing a 2" tall block under each side of the railing section to ensure the railing is installed straight. *Note: Be careful not to scratch the posts.*
3. Align the self-centering brackets and secure them to the post, by inserting the #10 screws into the holes on the bracket. Be sure that you do not overtighten the screws.
4. Fasten the brackets to the bottom rail using the #10 screws provided.

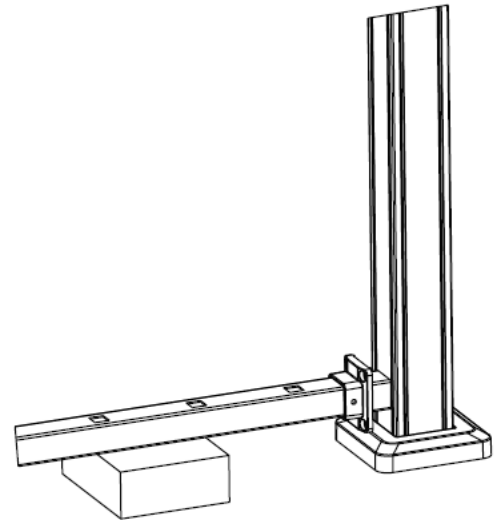

Section 4

1. Insert the spindles into the routed holes in the bottom rail. Lightly tap each spindle with a rubber mallet to ensure the spindles are properly set.
2. Hold the top rail at an upward angle and slowly line the spindles up with the routed holes in the top rail while lowering the rail into place.
3. Slide the brackets on to each end of the top rail, ensuring the back of the bracket is facing the posts.
4. Lightly tap the top rail with the rubber mallet to make sure spindles are properly set. Next, confirm the top rail is at the desired height and adjust if needed.
5. Align the self-centering brackets and secure them to the post, by inserting the #10 screws into the holes on the bracket. Do not overtighten the screws.
6. Fasten the brackets to the top rail using the #10 screws provided.
7. If needed, reduce the post height and install the post caps.

