

REVISIONS				
ECR/DCR	REV.	DESCRIPTION	DATE	APPD

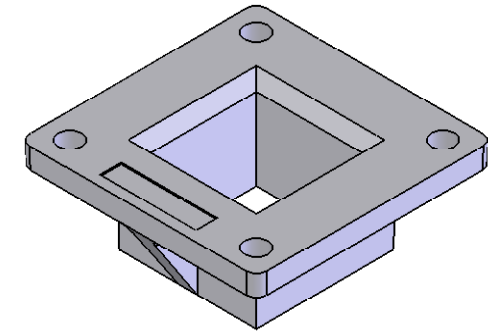

SECTION A-A

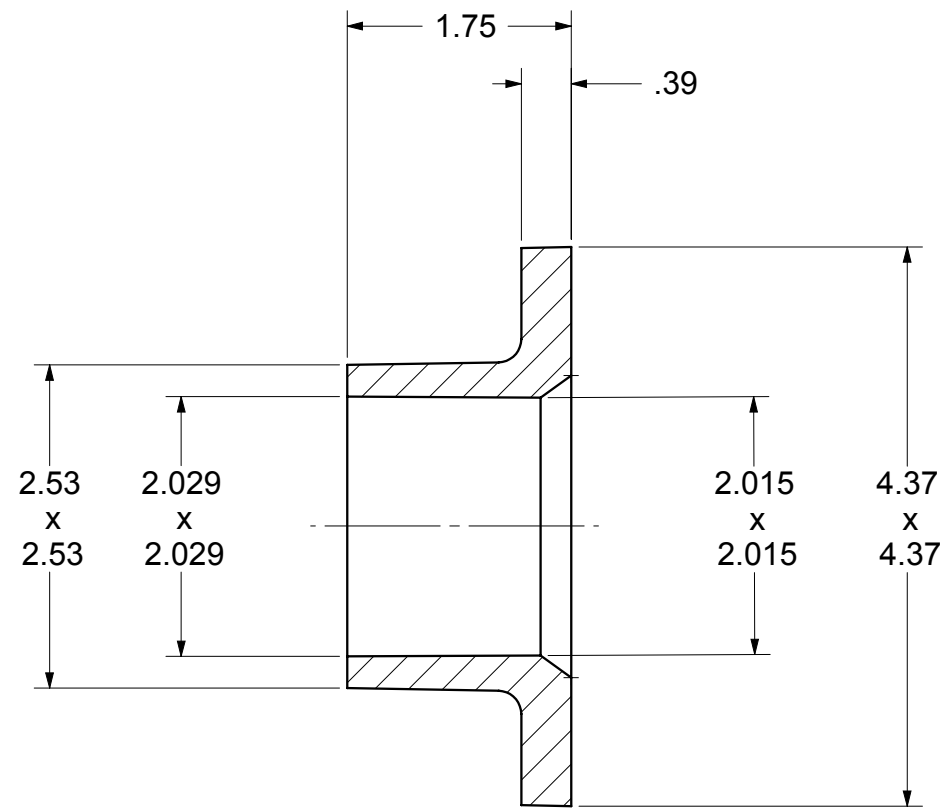
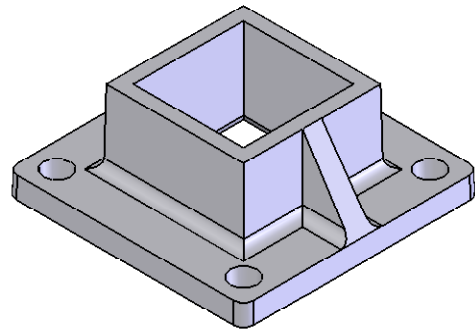
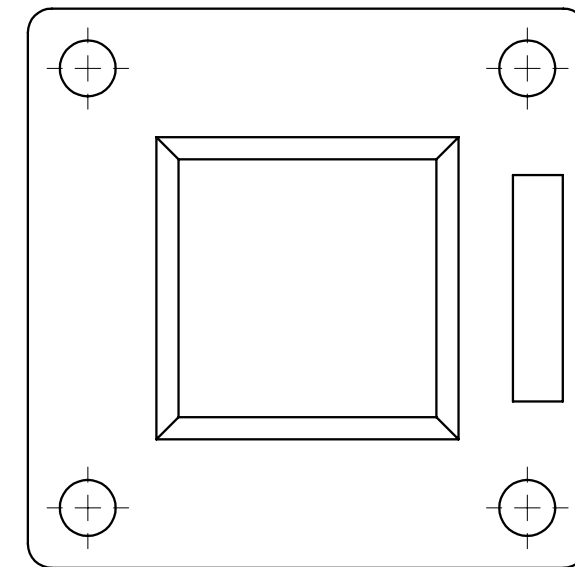
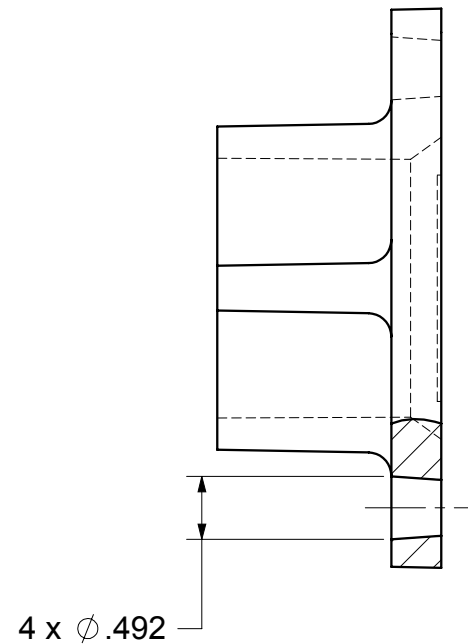
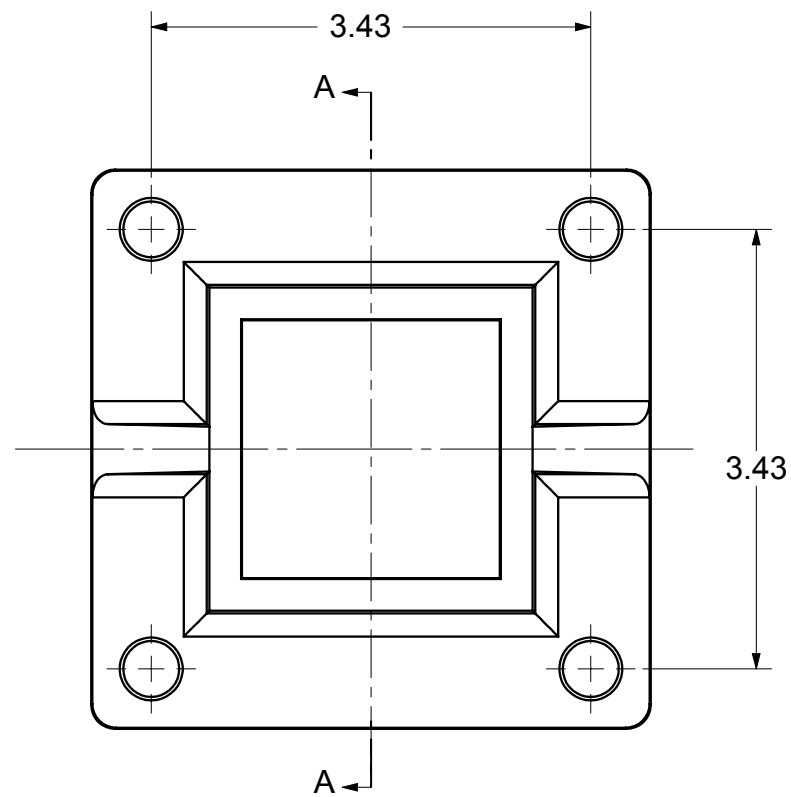

NOTES:

- PART TO HAVE A NON-ABRASIVE FINISH.
- PART TO HAVE MIN. DRAFT ANGLE AS TOOLING REQUIRES.
- ANY AND ALL CHANGES TO MATERIAL OR FINISH MUST BE APPROVED
- ALL DIAMETERS TO BE CONCENTRIC WITHIN .005 UNLESS OTHERWISE SPECIFIED.
- ALL CORNERS TO BE .015 MAX R OR CHAMFER OR OTHERWISE NOTED.
- ALL DIMENSIONS ARE FINISHED PART DIMENSIONS.
- PART VOLUME: 9.181 CU IN
- MATERIAL: A360 ALUMINUM

DIMENSIONS ARE IN INCHES
 TOLERANCES:
 FRACTIONAL ±1/16"
 ANGULAR: MACH ±1° BEND ±1°
 TWO PLACE DECIMAL ±0.01
 THREE PLACE DECIMAL ±0.005

2x2 FLOOR MOUNT BRACKET

AFF22BL

SIZE B	DWG. NO.	REV. -
SCALE: 1:1.5	WEIGHT:	SHEET 1 OF 1