

MAGNETIC TOP PULL LATCH

INSTALLATION, ADJUSTMENT AND MAINTENANCE INSTRUCTIONS

STEP 1: Determine mounting height based upon local code requirements.

STEP 2: Install the UPPER BRACKET as near to the top of the Fence Post as possible using (3) FlatHead Screws. (Fig. 2)

STEP 3: Install Lower Bracket

1. Slide the Latch Body down over the Upper Bracket (Fig. 3). Use a measuring device to locate the Top of the Latch at the PROPER HEIGHT (Fig. 1) "REFER TO ALL LOCAL BUILDING CODES"
2. Temporarily attach the Lower Bracket by holding it against the post and sliding it up into the Latch Body (Fig. 4). Center the mark on the Latch Body between the two marks on the Lower Bracket (Fig. 5). With the Latch at the PROPER HEIGHT, mark the Lower Bracket location on the Post.
3. Remove Latch Body and attach the Lower Bracket with the (4) supplied Flat Head mounting screws.

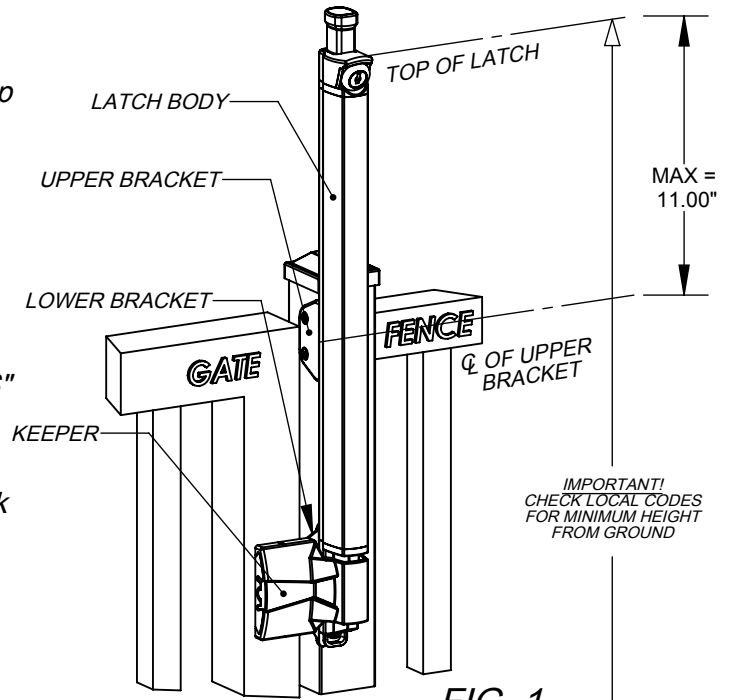

STEP 4: Install Latch Body

4. Re-install Latch Body by sliding over both Upper and Lower Brackets.
5. Position at proper height and secure with (1) #8 FlatHead Screw (Fig 6).

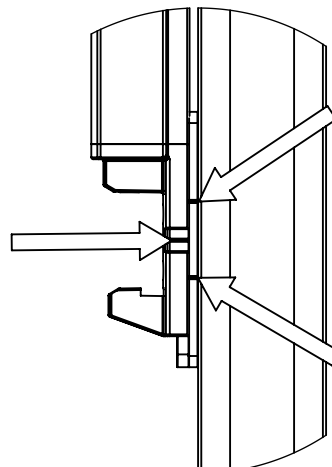
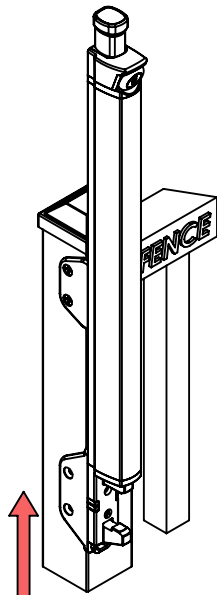
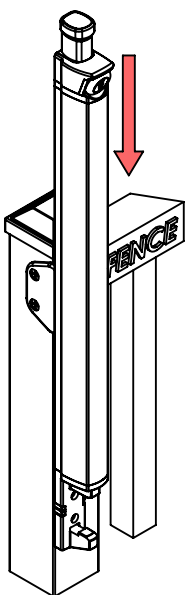
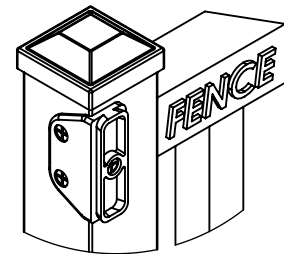

FIG. 5

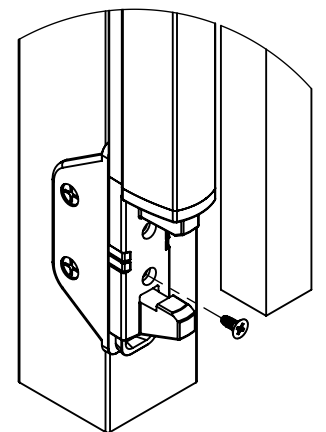

FIG. 6

MAGNETIC TOP PULL LATCH

INSTALLATION, ADJUSTMENT AND MAINTENANCE INSTRUCTIONS

STEP 5: Install Keeper Assembly

1. Adjust Keeper assembly (Fig. 12) to align with Latch Body (Fig. 7). Maximum operational adjustment has been reached when the line on the Keeper assembly reaches the gate face. (Fig. 11)
2. Position the mark on the Keeper Assembly between the two outer marks on the Latch Body (Fig. 8). The ideal location is closer to the top mark.
3. Secure Keeper Assembly to Gate in this position using (2) Flat Head screws as shown in (Fig. 9).
4. Open gate and adjust keeper assembly out to expose the remaining two screw locations (Fig. 10). Install (2) Flat Head screws then return Keeper Assembly back to proper alignment. (Fig. 7)

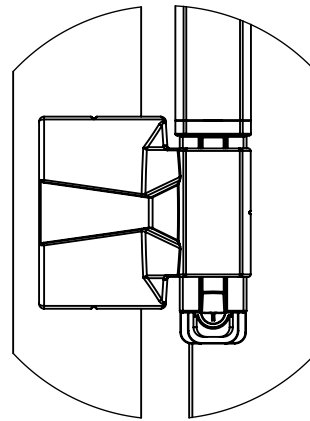

FIG. 7

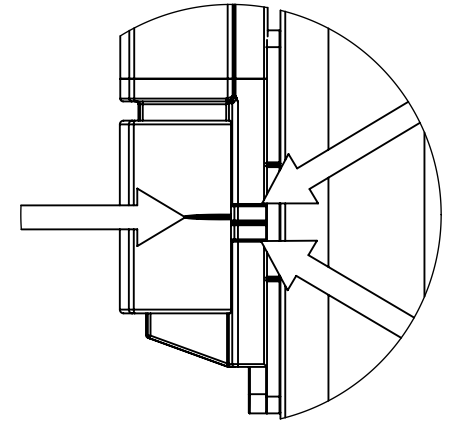

FIG. 8

STEP 6: Final Adjustments

1. Check for proper operation. If any final Adjustments are needed, use the Horizontal Adjustment screw located in the Keeper Assembly (Fig. 12), and / or the Vertical Adjustment holes located in the Lower Bracket (Fig. 13).

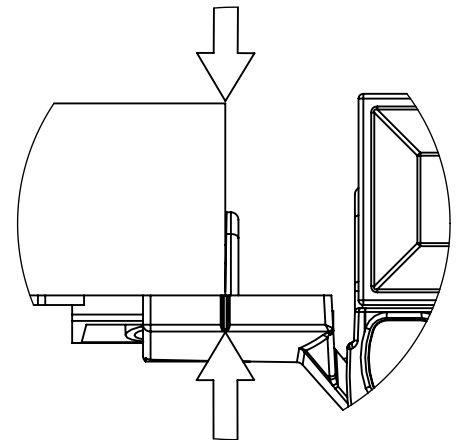

FIG. 11

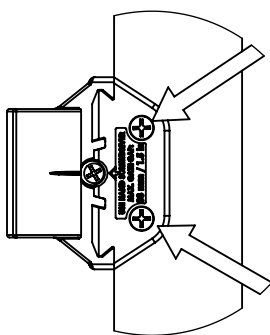

FIG. 9

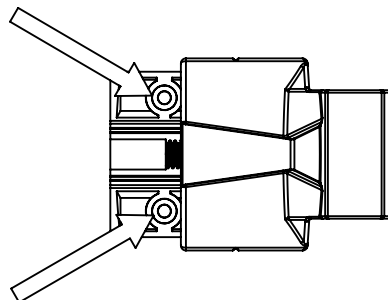

FIG. 10

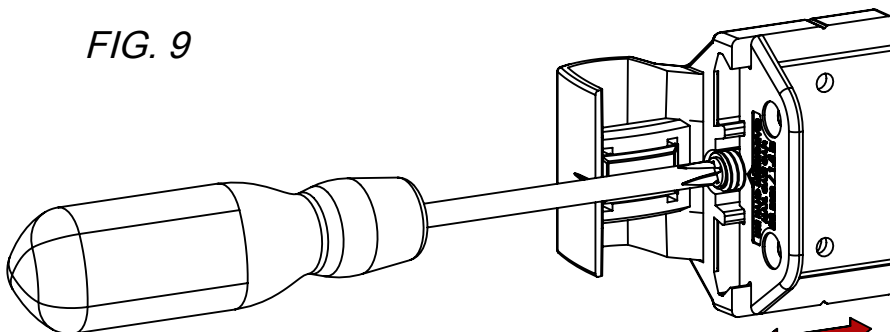

FIG. 12

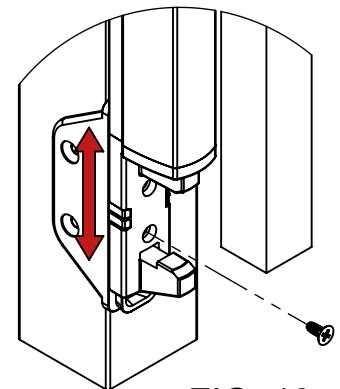

FIG. 13